

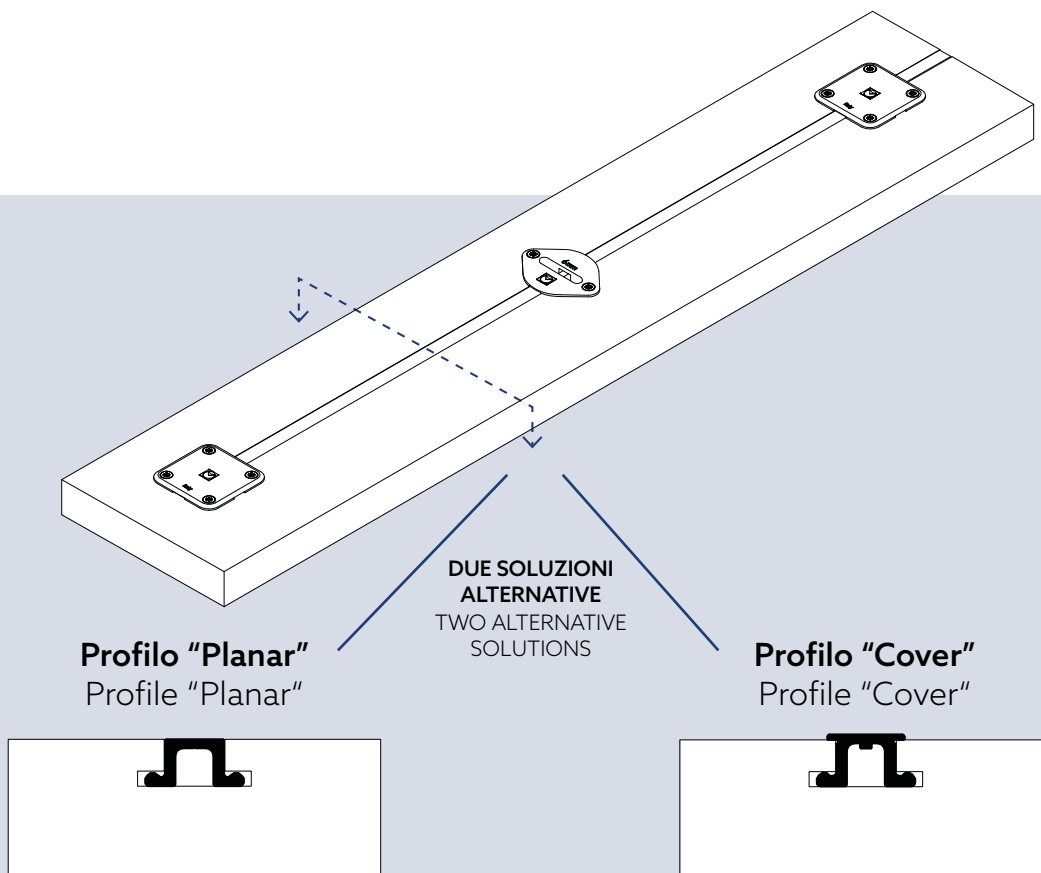

RADDRIZZA ANTE ESTERNO RE301 EXTERNAL STRAIGHTENER RE301



Specifiche tecniche

Technical specifications

- **Profilo di copertura in alluminio, coplanare PLANAR o con coprifilo COVER**
Aluminum covering profile, coplanar PLANAR or cover with profile COVER
- **Barra filettata e profilo di alluminio disponibili in 3 misure accorciabili**
Threaded bar and aluminum profile available in 3 sizes that can be shortened
- **Applicabile su pannelli di legno, agglomerati o tamburati**
Applicable on wooden, agglomerated or hollow cored panels
- **Regolazione centrale**
Central adjustment
- **Corsa di regolazione di 10 mm a tirare o spingere**
10 mm adjustment stroke by pulling or pushing
- **Spessore minimo del pannello 14 mm**
Minimum panel thickness 14 mm
- **Nessun rischio di fuoriuscita del profilo**
No risk of profile leakage
- **Veloce e semplice da adattare e installare**
Quick and simple to adapt and install

I raddrizza ante Celegon si collocano ai massimi livelli prestazionali e con un ottimo rapporto di qualità/prezzo.
Celegon door straighteners provide the highest performance and offer a great quality to price ratio.

Applicazione ed utilizzo

Application and use

Video installazione

Installation video



REF Q.TÀ DESCRIZIONE - DESCRIPTION

| | | |
|---|---|---|
| A | 1 | Boccola con coda - Bush with extension |
| B | 1 | Boccola centrale - Central bush |
| C | 1 | Boccola senza coda - Bush without extension |
| D | 1 | Regolatore - Regulator |
| E | 1 | Barra filettata M5 SX - Threaded bar M5 left |
| F | 1 | Barra filettata M5 DX - Threaded bar M5 right |
| G | 1 | Profilo alluminio Planar o Cover - Aluminium profile Planar o Cover |

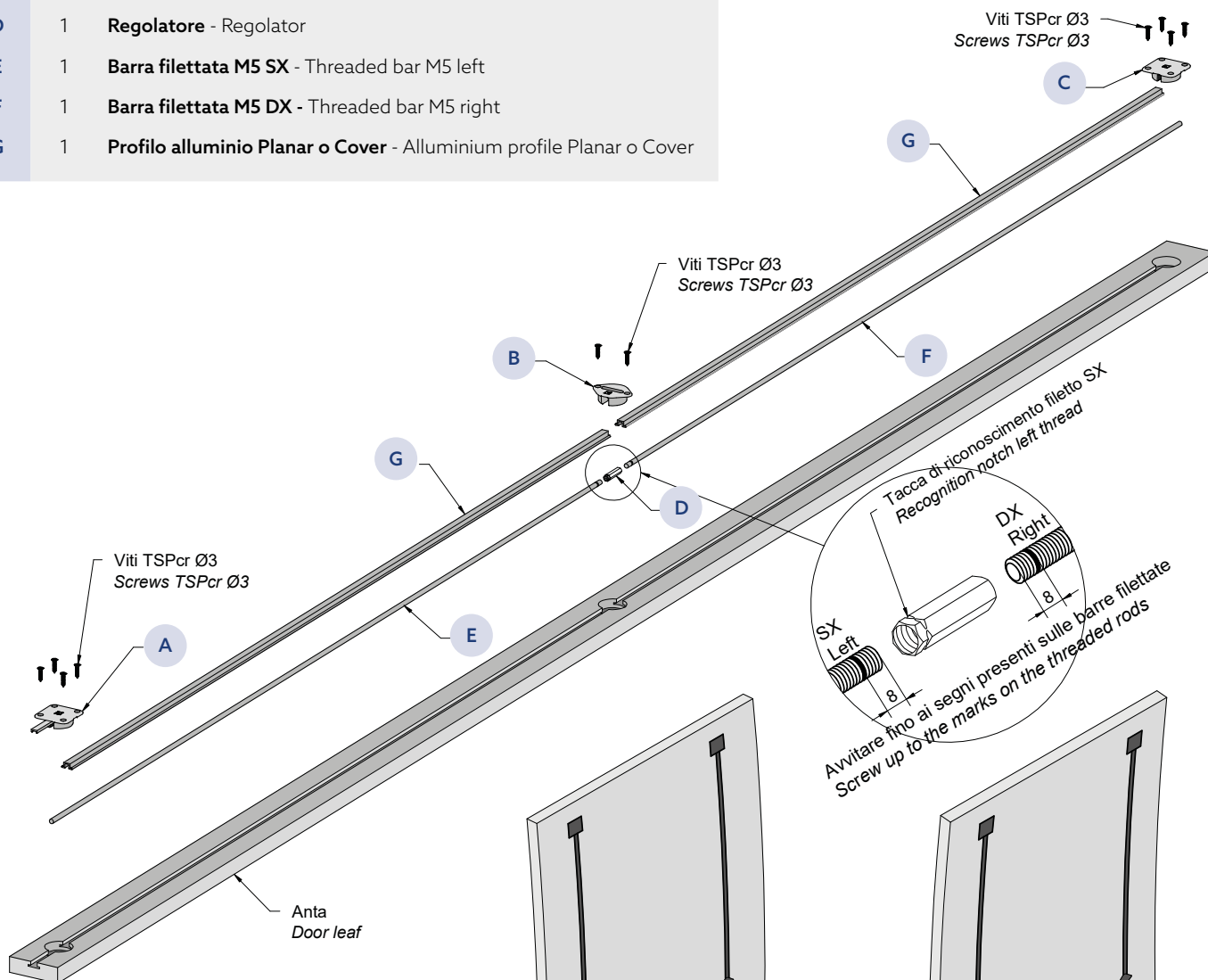

Attenzione

Quando è installato più di un raddrizza ante sulla stessa anta, controllare che tutte le barre filettate DX siano installate sullo stesso lato (superiore o inferiore).

Attention

When more than one straightener is installed on the same door leaf is to check carefully that all the right hand threaded bars are installed on the same side (top or bottom).

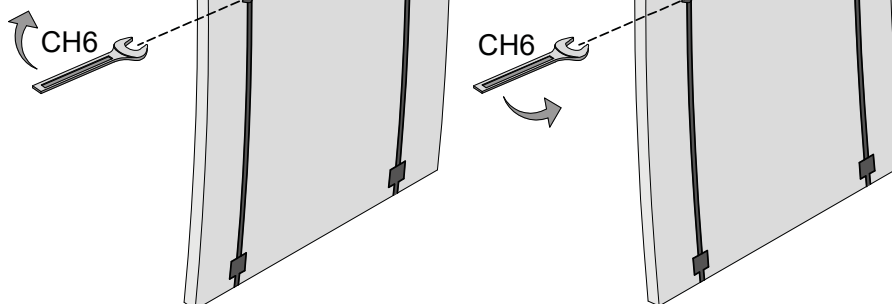

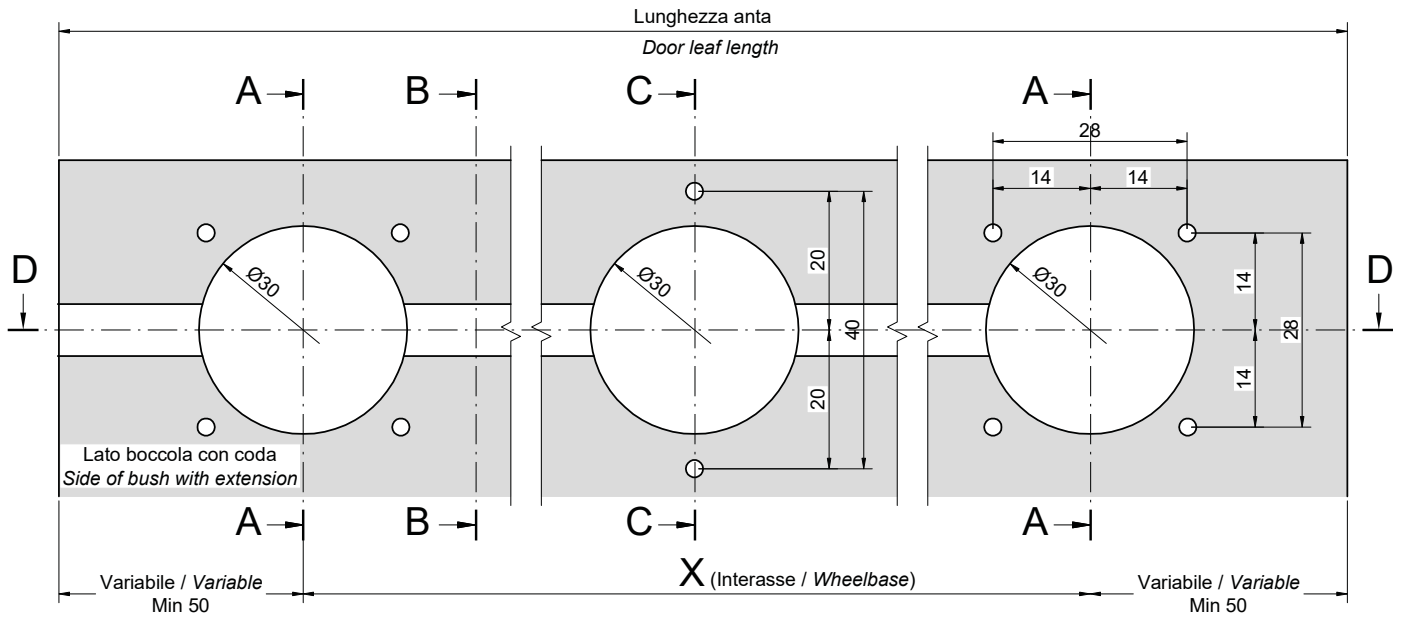

SEZIONI - SECTIONS

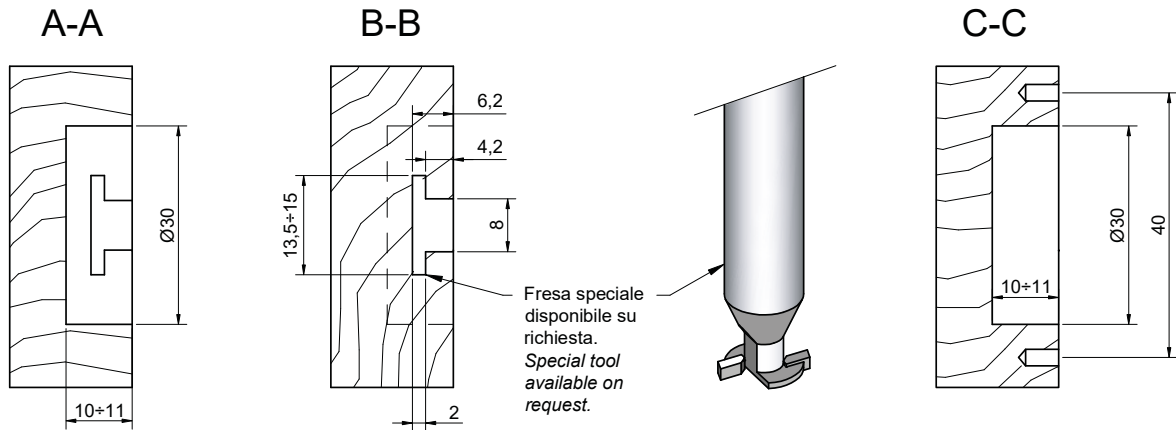

Attenzione

Sullo stesso raddrizza ante le quote X1 e X2 possono essere diverse tra loro.

Attention

On the same straightener the X1 and X2 dimensions can be different from each other.

L. X1-X2

max 1492 mm
max 1192 mm
max 992 mm

L. BARRA FILETTATA
L. THREADED BAR

1500 mm
1200 mm
1000 mm

MISURE DISPONIBILI, ACCORCIABILI
AVAILABLE SIZES, CAN BE SHORTENED

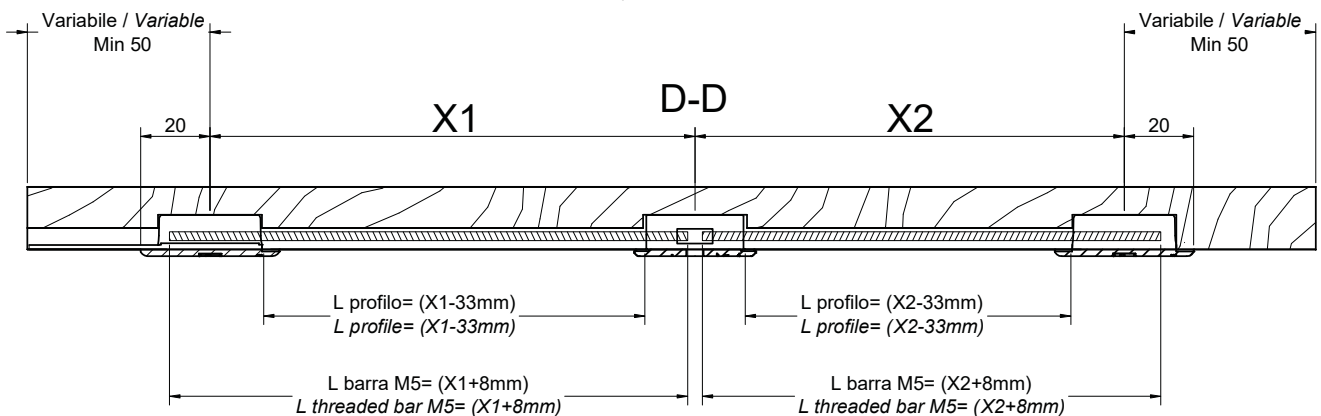

MADE IN ITALY



CELEGON S.r.l.

via Galileo Galilei, 6 Z.I.,
30035, Mirano (Venezia)

Italia

Tel +39-041-5728404

Email info@celegon.it

www.celegon.it