



+ MORE
SPACE
50%
- REDUCED
CLEARANCE

SOFT OPENING DAMPENING SYSTEM

The **Soft Opening** damper slows down leaf doors before they are fully open.

The **Soft Opening** system can be easily accessed and inspected.



PUSH&GO: DOORS OPEN WITH A CLICK MAGNETIC RELEASE SYSTEM FOR DOUBLE-LEAF DOORS



Push & Go EVO is the magnetic system that facilitates the release of the secondary leaf in double-leaf doors.

Push & Go EVO allows you to release the secondary leaf by simply pressing the button. The concealed magnetic system ensures that the door closes simply by accompanying the door leaf into position.



FOLDING DETACHABLE HINGES

Special Folding hinges are available for connecting the door leaves.

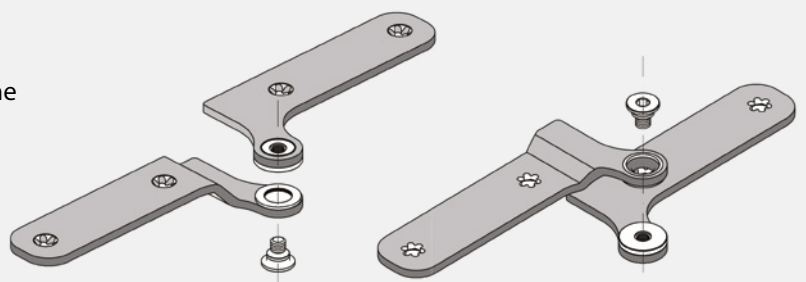

MOVABLE WALL SYSTEM

WITH PERIMETER FRAME



UP TO
6,5 MT
OF WIDTH

MINIMUM EFFORT WIDE OPENINGS

The door leaves move with minimum effort, opening and closing in seconds, ensuring unprecedented durability over time. The system can handle up to **5 door leaves + 1 single door leaf** with a width of up to 120 cm and a height of up to 300 cm for each individual door leaf.

SWING-AND- SLIDE OPENING

With ERGON® LIVING FOLDING, you can reorganise rooms, taking full advantage of the benefits of the swing-and-slide opening, also for very wide openings, with **architectural widths of up to 6.5 metres**. The special technique lets you partition spaces with a movement that is silent, stable and user-friendly.

ERGON® LIVING FOLDING, an innovative system from Celegon S.r.l., redefines the concept of living space.

The **special swing-and-slide hardware system** easily adapts to any door finish, offering a large number of options for application for those who need to design private and public interior spaces. It is ideal for closing niches, walk-in wardrobes or kitchen compartments, also for partitioning spacious rooms in private and public contexts.

THE FLOOR IS NEVER INVOLVED AS THERE ARE NO GUIDING OR SLIDING ELEMENTS.



Durability and reliability



**Made in Italy
patent**



**Easy to inspect
and install**

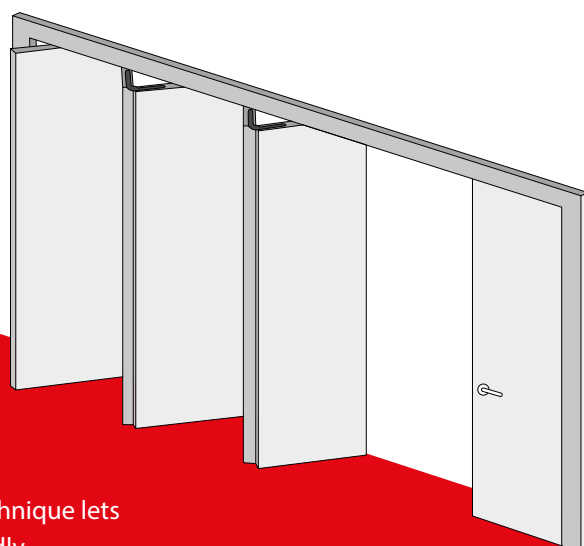



AVAILABLE OPENING COMBINATIONS

SINGLE OPENING

FOLDING DOORS

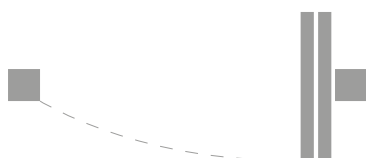

Set-up	No. doors	LFM min-max
A	2	1245 ÷ 2585
D	3	1990 ÷ 3790
H	4	2310 ÷ 4990
L	5	3195 ÷ 6195

DOUBLE OPENING

SINGLE DOOR + FOLDING DOORS

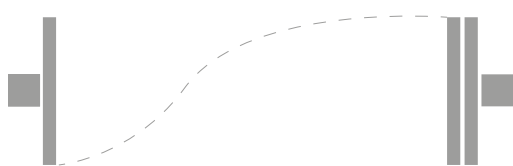

B	1 + 2	1910 ÷ 3780
E	1 + 3	2530 ÷ 4980
I	1 + 4	2975 ÷ 6185
M	1 + 5	3660 ÷ 6550

DOUBLE OPENING

FOLDING DOORS



C	2 + 2	2300 ÷ 4980
F	2 + 3	2925 ÷ 6185
G	3 + 3	3550 ÷ 6550

N.B. Other layouts are possible upon verification

SECTIONAL COMPONENTS

The system comes with a visible perimeter frame, **including all adjustments** for easy and optimal installation of the finished wall.

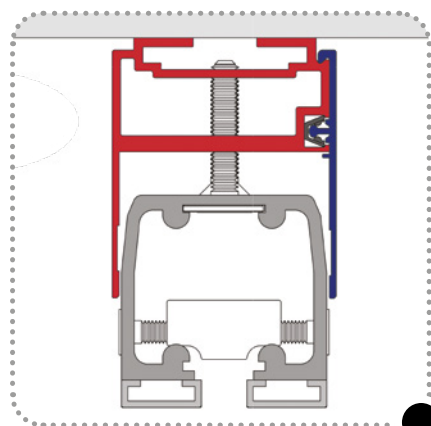

CEILING-MOUNTED
VERTICAL SECTION

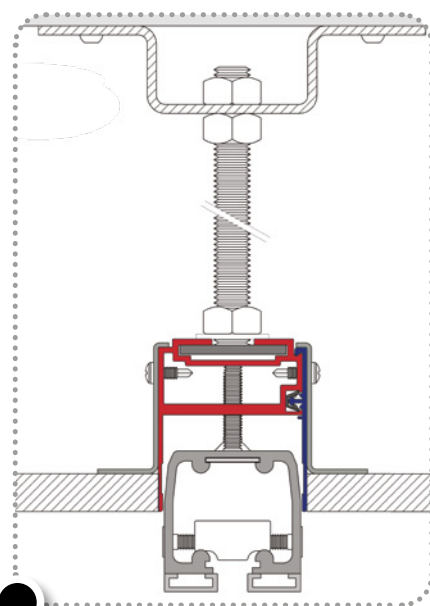

FALSE CEILING-MOUNTED
VERTICAL SECTION

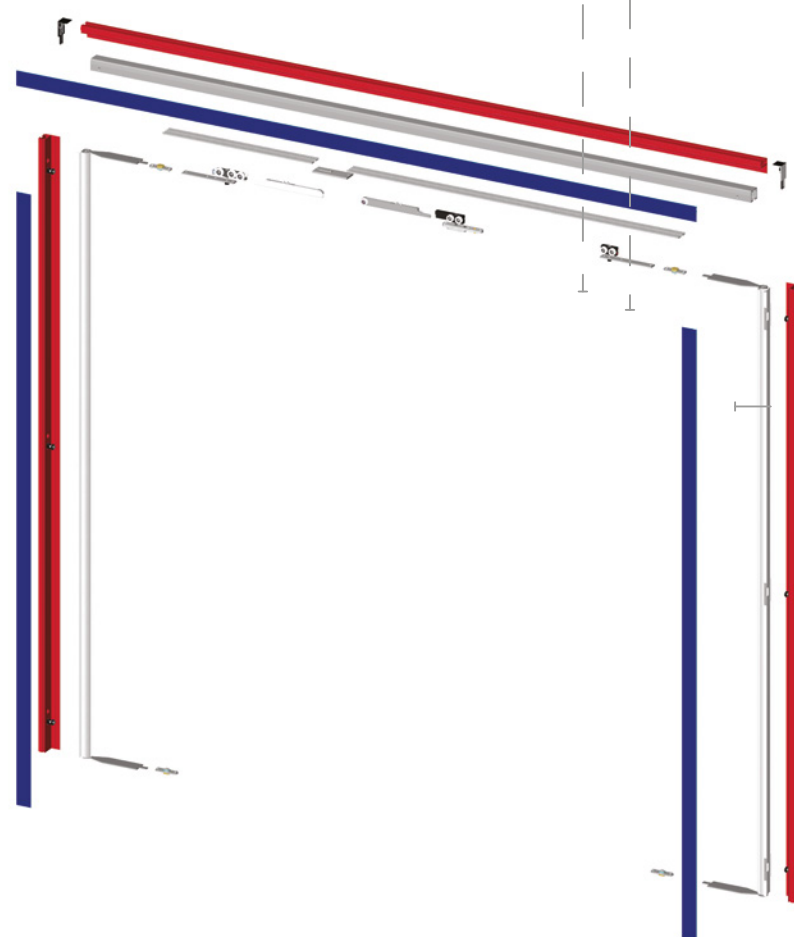

- External frame
- Trim for external frame

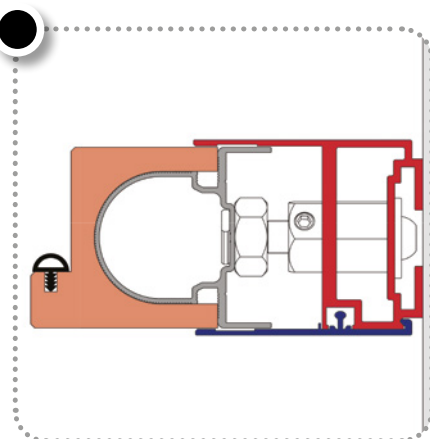

WALL-MOUNTED
HORIZONTAL SECTION

PATENTED
AN EXCLUSIVE IDEA BY CELEGON

ERGON® LIVING is a Celegon brand registered
in major international markets.





MADE IN ITALY



ERGON® LIVING FOLDING is an idea by CELEGON
30035 Mirano (Venezia) | Via G. Galilei, 6 - Z.I.
T +39 041 572 8404 | F +39 041 572 8522
www.celegon.it/en | info@celegon.it